

# FIXATION ELEMENTS

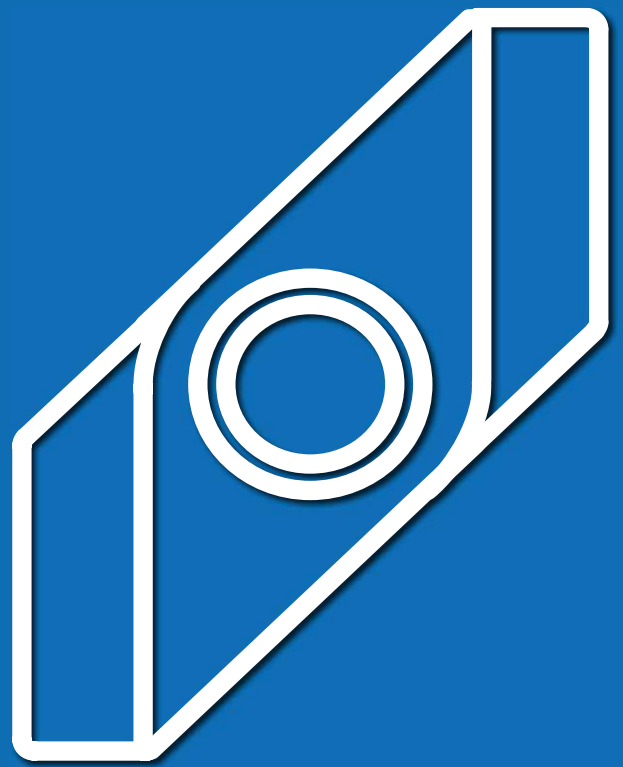









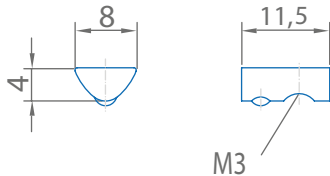

# FIXATION ELEMENTS

T-SLOTS ZN			
ITEM	Description	Order no.	Drawing
	<p>Suitable for efficient assembly of components in the profile groove. A fixed thread is created by tightening the T-slot. The T-slots Zn can be pre-assembled on the component to be fastened using a screw. After positioning the T-slot including with the screw in the profile slot, it locks automatically in the profile when tightened.</p>		
<b>T-slot 8 Zn M3</b> 	<p>Material: die-cast zinc            Surface: galvanised            m = 5,0 g</p>	<b>NS8-ZN-M3</b>	
<b>T-slot 8 Zn M4</b> 	<p>Material: die-cast zinc            Surface: galvanised            m = 5,0 g</p>	<b>NS8-ZN-M4</b>	
<b>T-slot 8 Zn M5</b> 	<p>Material: die-cast zinc            Surface: galvanised            m = 4,5 g</p>	<b>NS8-ZN-M5</b>	
<b>T-slot 8 Zn M6</b> 	<p>Material: die-cast zinc            Surface: galvanised            m = 4,0 g</p>	<b>NS8-ZN-M6</b>	

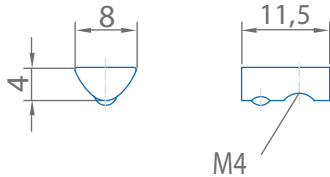

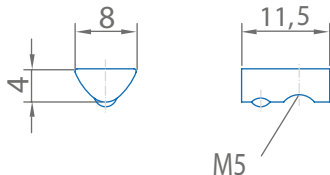









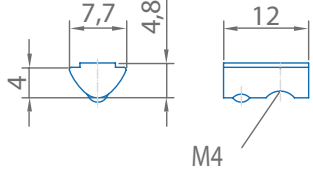

## T-SLOTS ST

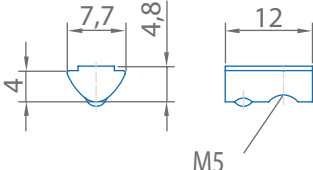
ITEM	Description	Order no.	Drawing
	<p>T-slot St for fastening medium-heavy components. The T-slots can be swivelled into the profile groove in any position. The fixing of the T-slot is made by means of a spring-loaded ball. T-slots St are offered as standard in St, galvanised. For special applications there is a stainless steel version (A2).</p>		
<b>T-slot 5 St M3</b> 	Material: St Surface: galvanised m = 2,0 g	<b>NS5-M3</b>	
<b>T-slot 5 St M4</b> 	Material: St Surface: galvanised m = 2,0 g	<b>NS5-M4</b>	
<b>T-slot 5 St M4, stainless</b> 	Material: stainless steel (A2) Surface: natural m = 2,0 g	<b>NS5-M4-R</b>	
<b>T-slot 5 St M5</b> 	Material: St Surface: galvanised m = 1,5 g	<b>NS5-M5</b>	
<b>T-slot 5 St M5, stainless</b> 	Material: stainless steel (A2) Surface: natural m = 1,5 g	<b>NS5-M5-R</b>	

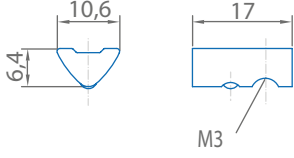

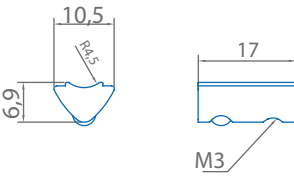

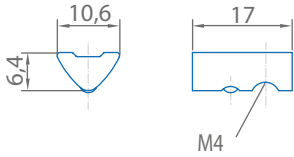

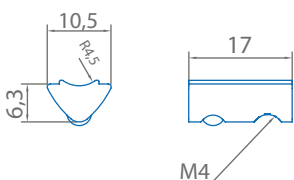

fixation elements

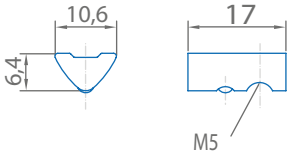

# FIXATION ELEMENTS

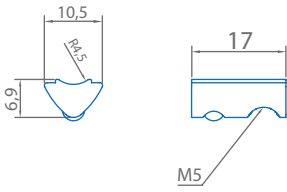

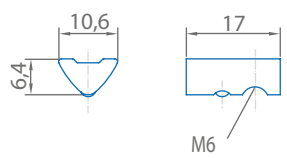

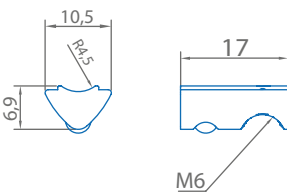

T-SLOTS ST			
ITEM	Description	Order no.	Drawing
	T-slots St with guiding ridge for fastening medium-heavy components. The T-slots can be swivelled into the profile groove in any position. The fixation of the T-slot is carried out via a spring-loaded ball. The attached guiding ridge prevents the T-slot from twisting in the profile groove.		
<b>T-slot 5 St M4 with guiding ridge</b> 	Material: St Surface: galvanised m = 2,0 g	<b>NS5-M4-STEG</b>	
<b>T-slot 5 St M5 with guiding ridge</b> 	Material: St Surface: galvanised m = 1,8 g	<b>NS5-M5-STEG</b>	
T-SLOTS ST			
ITEM	Description	Order no.	Drawing
	T-slots St for fastening medium-heavy components. The T-slots can be swivelled into the profile groove in any position. The fixing of the T-slot is made by means of a spring-loaded ball. T-slots St are offered as standard in St, galvanised. For special applications there is a stainless steel version (A2).		
<b>T-slot 6 St M3</b> 	Material: St Surface: verzinkt m = 4,5 g	<b>NS6-M3</b>	
<b>T-slot 6 St M3 with guiding ridge concave, galvanised</b> 	Material: St Surface: galvanised Version: guiding ridge, concave m = 5,2 g	<b>NS6-M3-STEG-K</b>	
<b>T-slot 6 St M4</b> 	Material: St Surface: galvanised m = 4,5 g	<b>NS6-M4</b>	
<b>T-slot 6 St M4 with guiding ridge concave, galvanised</b> 	Material: St Surface: galvanised Version: guiding ridge concave m = 5,2 g	<b>NS6-M4-STEG-K</b>	



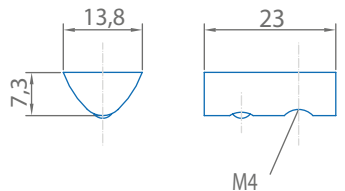

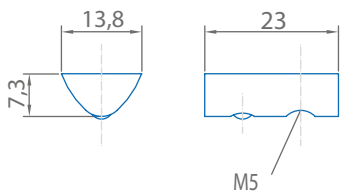

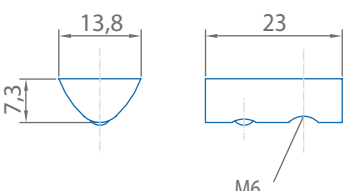
T-SLOTS ST			
ITEM	Description	Order no.	Drawing
			
<b>T-slot 6 St M5</b>			
	Material: St Surface: galvanised m = 4,5 g	<b>NS6-M5</b>	
<b>T-slot 6 St M5, stainless</b>			
	Material: stainless steel (A2) Surface: natural m = 4,5 g	<b>NS6-M5-R</b>	
<b>T-slot 6 St M5 with guiding ridge, galvanised</b>			
	Material: St Surface: galvanised Version: guiding ridge, concave m = 5,2 g	<b>NS6-M5-STEГ-K</b>	
<b>T-slot 6 St M6</b>			
	Material: St Surface: galvanised m = 4,0 g	<b>NS6-M6</b>	
<b>T-slot 6 St M6, stainless</b>			
	Material: stainless steel (A2) Surface: natural m = 4,0 g	<b>NS6-M6-R</b>	
<b>T-slot 6 St M6 with guiding ridge concave, galvanised</b>			
	Material: St Surface: galvanised Version: guiding ridge, concave m = 5,2 g	<b>NS6-M6-STEГ-K</b>	



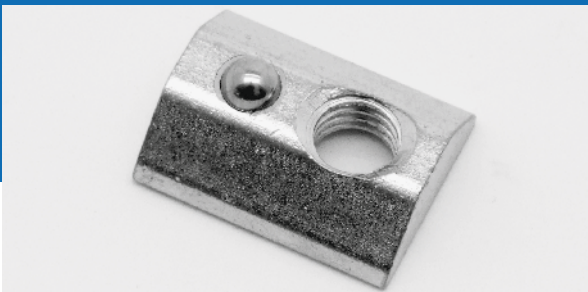

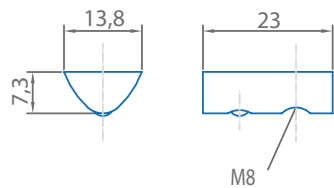

# FIXATION ELEMENTS

T-SLOTS ST				
ITEM	Description	Order no.	Drawing	
	T-slots St for fastening medium-heavy components. The T-slots can be swivelled into the profile groove in any position. The fixing of the T-slot nut is made by means of a spring-loaded ball. T-slots St are offered as standard in St, galvanised. For special applications there is a stainless steel version (A2).			
<b>T-slot 8 St M4</b>		<b>NS8-M4</b>		
	Material: St Surface: galvanised m = 11,5 g			
<b>T-slot 8 St M4, stainless</b>		<b>NS8-M4-R</b>		
	Material: stainless steel (A2) Surface: natural m = 11,0 g			
<b>T-slot 8 St M5</b>		<b>NS8-M5</b>		
	Material: St Surface: galvanised m = 11,0 g			
<b>T-slot 8 St M5, stainless</b>		<b>NS8-M5-R</b>		
	Material: stainless steel (A2) Surface: natural m = 10,5 g			
<b>T-slot 8 St M6</b>		<b>NS8-M6</b>		
	Material: St Surface: galvanised m = 11,0 g			
<b>T-slot 8 St M6, stainless</b>		<b>NS8-M6-R</b>		
	Material: stainless steel (A2) Surface: natural m = 10,5 g			

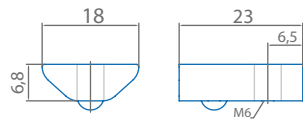

T-SLOTS ST			
ITEM	Description	Order no.	Drawing
			
<b>T-slot 8 St M8</b>		<b>NS8-M8</b>	
	Material: St Surface: galvanised m = 10,0 g		
<b>T-slot 8 St M8, stainless</b>		<b>NS8-M8-R</b>	
	Material: stainless steel (A2) Surface: natural m = 9,5 g		

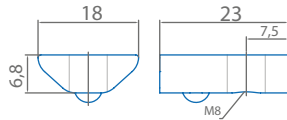
Fixation  
elementes





T-SLOTS ST HEAVY			
ITEM	Description	Order no.	Drawing
	T-slots St heavy are used for particularly high loads. Since the T-slot is adapted to the contour of the profile slot, forces are generated optimally introduced into the aluminium profile. T-slots heavy are inserted into the groove from the end face of a profile. Against shifting they are axially secured by a spring-loaded ball.		
<b>T-slot 8 St M6 heavy</b>		<b>NS8-M6-S</b>	
	Material: St Surface: galvanised m = 14,5 g		
<b>T-slot 8 St M8 heavy</b>		<b>NS8-M8-S</b>	
	Material: St Surface: galvanised m = 13,0 g		



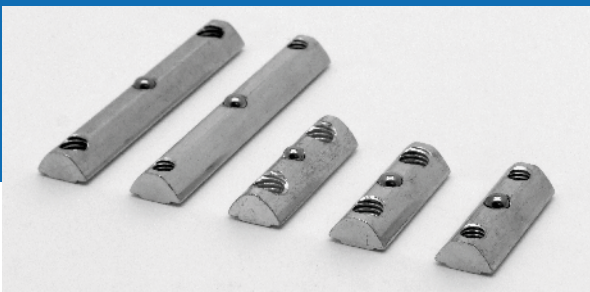



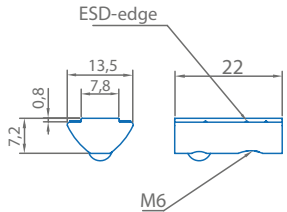

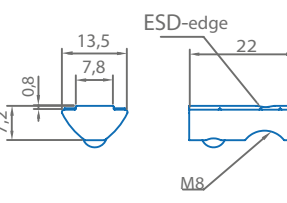
# FIXATION ELEMENTS

T-SLOTS WITH GUIDING RIDGE			
ITEM	Description	Order no.	Drawing
	T-slots St with guiding ridge for fastening medium-heavy components. The T-slots can be swivelled into the profile groove in any position. The fixation of the T-slots is carried out via a spring-loaded ball. The attached guiding ridge prevents the T-slots from twisting in the profile groove.		
<b>T-slot 8 St M3 with guiding ridge</b> 	Material: St Surface: galvanised m = 11,5 g	<b>NS8-M3-STEg</b>	
<b>T-slots 8 St M4 with guiding ridge</b> 	Material: St Surface: galvanised m = 11,0 g	<b>NS8-M4-STEg</b>	
<b>T-slot 8 St M5 with guiding ridge</b> 	Material: St Surface: galvanised m = 10,5 g	<b>NS8-M5-STEg</b>	
<b>T-slot 8 St M6 with guiding ridge</b> 	Material: St Surface: galvanised m = 10,5 g	<b>NS8-M6-STEg</b>	
<b>T-slot 8 St M8 with guiding ridge</b> 	Material: St Surface: galvanised m = 9,5 g	<b>NS8-M8-STEg</b>	

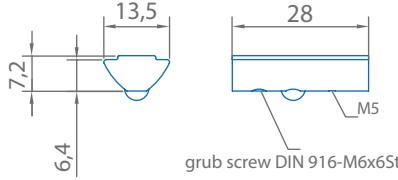

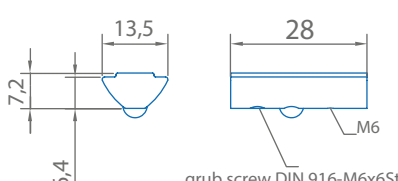
T-SLOTS ESD			
ITEM	Description	Order no.	Drawing
	ESD T-slots St have an upsetting on the upper side, which allows a conductive connection between the basic profile and the add-on part. The T-slots can be swivelled into the profile groove in any position and are used for fastening medium-heavy components. The T-slot is fixed by means of a spring-loaded ball. The attached guiding ridge prevents the T-slot from twisting in the profile groove.		
<b>T-slot 8 St M6 with guiding ridge ESD</b> 	Material: St Surface: galvanised m = 10,0 g	<b>NS8-M6-STEG-ESD</b>	
<b>T-slot 8 St M8 with guiding ridge ESD</b> 	Material: St Surface: galvanised m = 9,0 g	<b>NS8-M8-STEG-ESD</b>	

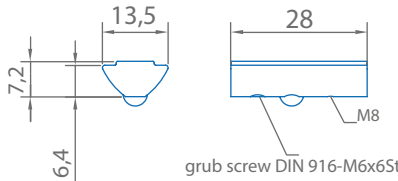
T-SLOTS F			
ITEM	Description	Order no.	Drawing
	The T-slot F provides a conductive connection between the mounting point and the profile. Furthermore, the T-slot F remains in place due to the tightening process of the grub screw in fixed position.		
<b>T-slot F 8 St M5 with guiding ridge</b> 	Material: St Surface: galvanised Grub screw DIN 916-M6x6 m = 13,0 g	<b>NS-F8-M5-STEG</b>	
<b>T-slot F 8 St M6 with guiding ridge</b> 	Material: St Surface: galvanised Grub screw DIN 916-M6x6 m = 12,5 g	<b>NS-F8-M6-STEG</b>	
<b>T-slot F 8 St M8 with guiding ridge</b> 	Material: St Surface: galvanised Grub screw DIN 916-M6x6 m = 12,0 g	<b>NS-F8-M8-STEG</b>	

Fixation elements







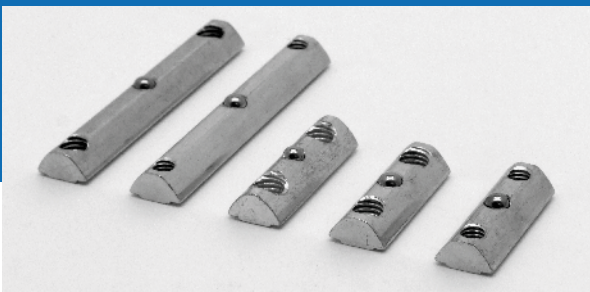



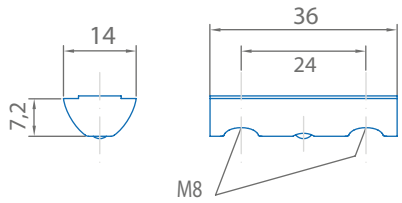

# FIXATION ELEMENTS

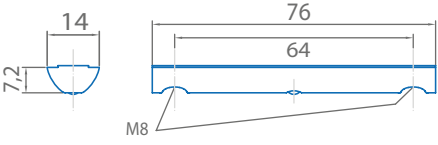
DOUBLE T-SLOTS			
ITEM	Description	Order no.	Drawing
	<p>Double T-slots are preferably used in conjunction with angled elements, universal and threaded form connectors for the fastening of profiles. However, they can also be used to fix a thread in the profile groove using a grub screw.</p>		
<b>T-slot 6 St 2xM5-28, galvanised</b> 	<p>Material: St            Surface: galvanised            Length: 28,0 mm            Hole separation: 19,0 mm            m = 7,5 g</p>	<b>NS6-2xM5-28</b>	
<b>T-slot 6 St 2xM5-58, galvanised</b> 	<p>Material: St            Surface: galvanised            Length: 58,0 mm            Hole separation: 49,0 mm            m = 17,0 g</p>	<b>NS6-2xM5-58</b>	
<b>T-slot 6 St 2xM6-28, galvanised</b> 	<p>Material: St            Surface: galvanised            Length: 28,0 mm            Hole separation: 17,0 mm            m = 7,0 g</p>	<b>NS6-2xM6-28</b>	
<b>T-slot 6 St 2xM6-58, galvanised</b> 	<p>Material: St            Surface: galvanised            Length: 58,0 mm            Hole separation: 47,0 mm            m = 15,5 g</p>	<b>NS6-2xM6-58</b>	
<b>T-slot 8 St 2xM6-36 with guiding ridge, galvanised</b> 	<p>Material: St            Surface: galvanised            Length: 36,0 mm            Hole separation: 26,4 mm            m = 16,0 g</p>	<b>NS8-2xM6-36-STEG</b>	
<b>T-slot 8 St 2xM6-76 with guiding ridge, galvanised</b> 	<p>Material: St            Surface: galvanised            Length: 76,0 g            Hole separation: 66,4 mm            m = 37,5 g</p>	<b>NS8-2xM6-76-STEG</b>	

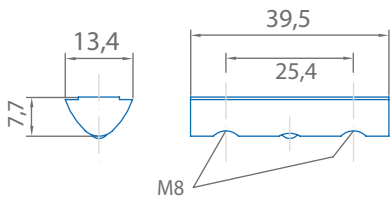

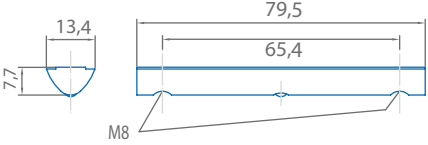
**DOUBLE T-SLOTS ST**

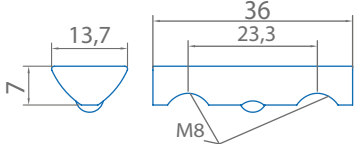
ITEM	Description	Order no.	Drawing
			
 <p><b>T-slot 8 St 2xM8-36 with guiding ridge, galvanised</b></p>	<p>Material: St                      Surface: galvanised                      Length: 36,0 mm                      Hole separation: 24,0 mm                      m = 14,0 g</p>	<b>NS8-2xM8-36-STEG</b>	
 <p><b>T-slot 8 St 2xM8-76 with guiding ridge, galvanised</b></p>	<p>Material: St                      Surface: galvanised                      Length: 76,0 mm                      Hole separation: 64,0 mm                      m = 36,5 g</p>	<b>NS8-2xM8-76-STEG</b>	
 <p><b>T-slot 8 St 2xM8-39,5 with guiding ridge, galvanised</b></p>	<p>Material: St                      Surface: galvanised                      Length: 39,5 mm                      Hole separation: 25,4 mm                      m = 15,5 g</p>	<b>NS8-2xM8-39,5</b>	
 <p><b>T-slot 8 St 2xM8-79,5 with guiding ridge, galvanised</b></p>	<p>Material: St                      Surface: galvanised                      Length: 39,5 mm                      Hole separation: 25,4 mm                      m = 15,5 g</p>	<b>NS8-2xM8-79,5</b>	
 <p><b>T-slot 8 St 2xM8-36-23,3, galvanised</b></p>	<p>Material: St                      Surface: galvanised                      Length: 36,0 mm                      Hole separation: 23,3 mm                      m = 14,0 g</p>	<b>NS8-2xM8-36-23,3</b>	



# FIXATION ELEMENTS











SCREW STRIP			
ITEM	Description	Order no.	Drawing
	Screw strips are inserted into the profile groove from above and allow light components to be fastened using thread-forming screws.		
<b>Screw strip 8 Al</b> 	Material: Al Surface: anodised 1 rod á 2.000 mm m = 130,0 g/m	<b>SL-8-AL</b>	
ANGLE BRACKETS / BRACKETS			
ITEM	Description	Order no.	Drawing
	Fixation elements for stable connection of profiles, surface elements, cable ducts or other components to each other or mutual.		
<b>Angle bracket 5 20, black</b> 	Material: St Surface: black powder-coated m = 13,5 g	<b>LCH5-20</b>	
<b>Bracket 5 20, black</b> 	Material: St Surface: black powder-coated m = 14,5 g	<b>W5-20-SCH</b>	
<b>Fastening set 5 for bracket 5 20 / angle bracket 5 20</b> 	2 countersunk screws DIN 7991-M5x8, St Surface: black burnished 2 T-slots 5 St M5, galvanised m = 6,5 g	<b>BS5-WL</b>	

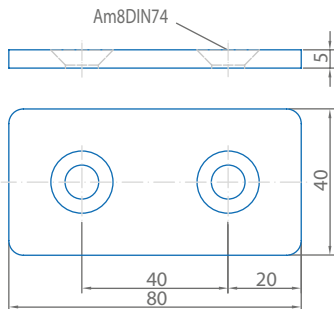

ANGLE BRACKETS / BRACKETS			
ITEM	Description	Order no.	Drawing
	Fixation elements for stable connection of profiles, surface elements, cable ducts or other components to each other or mutual.		
<b>Angle bracket 6 30, black</b> 	Material: St Surface: black powder-coated m = 38,0 g	<b>LCH6-30</b>	
<b>Angle bracket 6 30, stainless</b> 	Material: stainless steel (A2) Surface: natural m = 38,0 g	<b>LCH6-30-RF</b>	
<b>Bracket 6 30, black</b> 	Material: St Surface: black powder-coated m = 35,0 g	<b>W6-30-SCH</b>	
<b>Bracket 6 30, stainless</b> 	Material: stainless steel (A2) Surface: natural m = 33,0 g	<b>W6-30-RF</b>	
<b>Fastening set 6 for bracket 6 30 / angle bracket 6 30</b> 	2 countersunk screws DIN 7991-M6x10, St Surface: black burnished 2 T-slots 6 St M6, galvanised m = 13,5 g	<b>BS6-WL</b>	

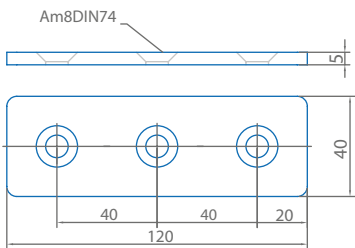

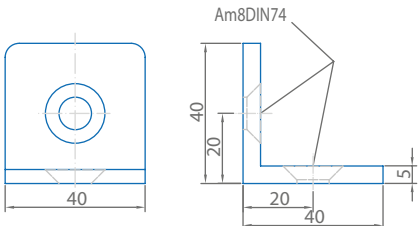
# FIXATION ELEMENTS

ANGLE BRACKETS / BRACKETS			
ITEM	Description	Order no.	Drawing
	Fixation elements for stable connection of profiles, surface elements, cable ducts or other components among each other or mutual.		
<b>Angle bracket 8 40, black</b> 	Material: St Surface: black powder-coated m = 114,0 g	<b>LCH8-40</b>	
<b>Angle bracket 8 40, stainless</b> 	Material: stainless steel (A2) Surface: natural m = 115,5 g	<b>LCH8-40-RF</b>	
<b>Angle bracket 8 40, galvanised</b> 	Material: St Surface: galvanised m = 110,5 g	<b>LCH8-40-VERZ</b>	
<b>Angle bracket 8 120x40, black</b> 	Material: St Surface: black powder-coated m = 175,5 g	<b>LCH8-120x40</b>	
<b>Bracket 8 40, black</b> 	Material: St Oberfläche: schwarz pulverbeschichtet m = 108,0 g	<b>W8-40-SCH</b>	
<b>Bracket 8 40, stainless</b> 	Material: stainless steel (A2) Surface: natural m = 100,0 g	<b>W8-40-RF</b>	
<b>Bracket 8 40, galvanised</b> 	Material: St Surface: galvanised m = 112,5 g	<b>W8-40-VERZ</b>	

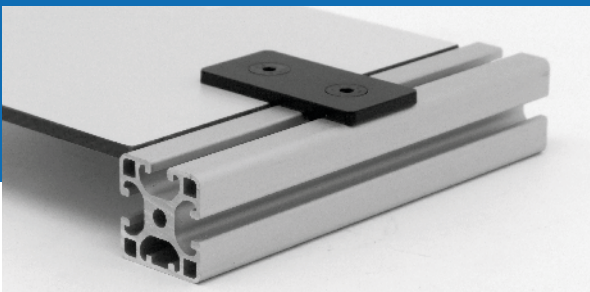

ANGLE BRACKETS / BRACKETS			
ITEM	Description	Order no.	Drawing
	Fastening set for bracket and angle bracket.		
<b>Fastening set 8 for bracket 8 40 / Angle bracket 8 40, black</b> 	2 countersunk screws DIN 7991-M8x14, St Surface: black burnished 2 T-slots 8 St M8, galvanised m = 32,5 g	<b>BS8-WL</b>	
<b>Fastening set 8 for bracket 8 40 / angle bracket 8 40, stainless</b> 	2 countersunk screws DIN7991-M8x14, St stainless steel (A2) 2 T-slots 8 StM8, stainless steel, stainless steel (A2) m = 32,5 g	<b>BS8-WL-RF</b>	
<b>Fastening set 8 for bracket 8 40 / angle bracket 8 40, galvanised</b> 	2 countersunk screws DIN 7991-M8x14, St Surface: black galvanised 2 T-slots 8 StM8, galvanised m = 33,0 g	<b>BS8-WL-VZ</b>	



# FIXATION ELEMENTS

FIXATION BRACKETS ZN			
ITEM	Description	Order no.	Drawing
	<p>Universal brackets Zn for fastening any component to aluminium profiles. Slots allow for a wide range of adjustment in position and incline. Screws up to size M6 may be used for fastening.</p>		
<b>Fixation bracket 40x40x20 Zn</b>  	<p>Material: die-cast zinc Surface: black powder-coated m = 58,5 g</p>	<b>BW-40x40x20-ZN</b>	
<b>Fixation bracket 60x40x20 Zn</b>  	<p>Material: die-cast zinc Surface: black powder-coated m = 73,0 g</p>	<b>BW-60x40x20-ZN</b>	
<b>Fixation bracket 60x60x20 Zn</b>  	<p>Material: die-cast zinc Surface: black powder-coated m = 87,0 g</p>	<b>BW-60x60x20-ZN</b>	
<b>Fixation bracket 80x40x20 Zn</b>  	<p>Material: die-cast zinc Surface: black powder-coated m = 85,5 g</p>	<b>BW-80x40x20-ZN</b>	

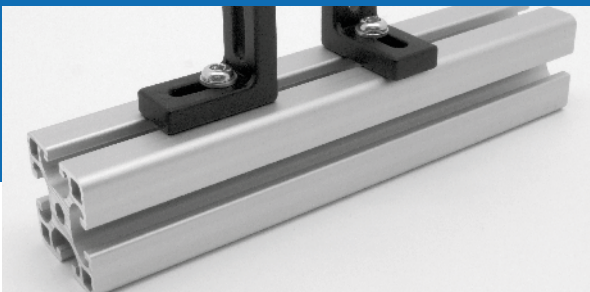

REBATE PROFILES			
ITEM	Description	Order no.	Drawing
	<p>Rebate profiles are swivelled into the groove and fixated using thread pins. The rebate profile 8 Al 19" is used for mounting 19" front plates or casings. The mounting components are fastened using captive nuts.</p>		
<b>Rebate profile 8 Al</b> 	<p>Material: Al          Surface: anodised          Cut max.: 6.000 mm          Rods: 3.000 / 6.000 mm          m = 321,0 g/m</p>	<p><b>WL8</b></p>	
<b>Rebate profile 8 Al M6</b> 	<p>Material: Al          Surface: anodised          Cut max.: 2.000 mm          Rod á 2.000 mm          m = 325,0 g/m</p>	<p><b>WL8-M6</b></p>	
<b>Rebate profile 8 Al 19"</b> 	<p>Material: Al          Surface: anodised          incl. grub screws DIN 913-M6x12, St          Rods á 2.048,0 mm          m = 281,3 g/m</p>	<p><b>WL8-AL-19</b></p>	



# FIXATION ELEMENTS

CAPTIVE NUTS			
ITEM	Description	Order no.	Drawing
	<p>Universal captive nuts for mounting an rebate profile 8 Al 19" or other surface elements. Simple and quick assembly due to snapping into the corresponding notch.</p>		
<p><b>Captive nut M5</b></p>	<p>Captive nut M5 Material: St Surface: galvanised m = 5,0 g</p>	<p><b>KM8-M5</b></p>	
<p><b>Captive nut M6</b></p>	<p>Captive nut M6 Material: St Surface: galvanised m = 5,0 g</p>	<p><b>KM8-M6</b></p>	
	<p>Surface pavement according to the machinery directive 2006/42/EC. The safety fastening and the panel element form an inseparable unit after installation. A loosened screw is inevitably indicated by the position of the panel element. The multiblock is suitable for a surface thickness of 3 to 8 mm.</p>		
<p><b>Multiblock 8 PA M6 with safety mounting, black</b></p>	<p>Base body Material: PA-GF Colour: black Fixing screw M6x22 St, galvanised Square nut DIN 557-M6, St, galvanised Captive washer M6 PA-GF, black Load: max. 250 N m = 20,5 g</p>	<p><b>MB8-PA-M6-SB</b></p>	

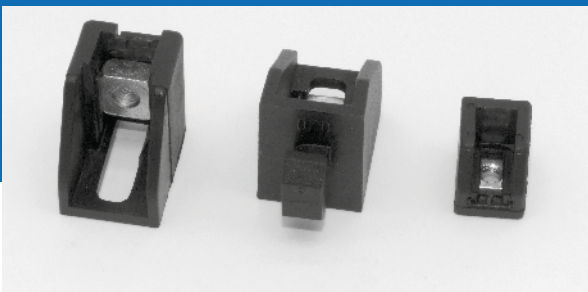



UNI BLOCKS			
ITEM	Description	Order no.	Drawing
	Uni blocks enable reliable fastening of any surface element to the groove. Uni blocks can always be used at a later time. Select the mounting location freely by rotating into the profile groove. A slot and a movable securing groove ensure a wide mounting margin.		
<b>Uni block 5 PA M4</b>			
	Base plate PA-GF, black Square nut M4, St, galvanised m = 2,5 g	<b>UB-5-PA-M4</b>	
<b>Uni block 8 PA M4</b>			
	Base plate PA-GF, black Square nut M4, St, galvanised m = 10,5 g	<b>UB-8-PA-M4</b>	
	This version of the uniblock is particularly suitable as a fastening element between table tops and connected surface elements.		
<b>Uni block slot PA M4</b>			
	Base plate PA-GF, black Square nut M4, St, galvanised m = 9,0 g	<b>UB-LL-PA-M4</b>	

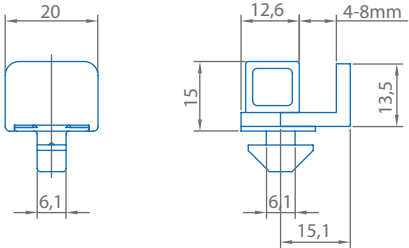

# FIXATION ELEMENTS

## UNI TERMINAL BLOCKS

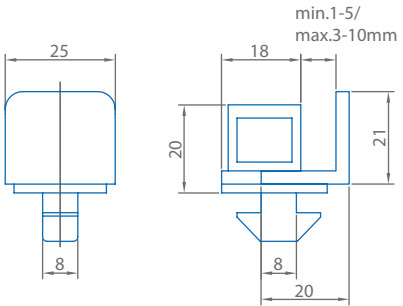
ITEM	Description	Order no.	Drawing
	<p>The uni terminal blocks are used for simple installation of surface elements. The terminal block can be installed into existing constructions using the insert-rotate principle at a later time. The surface element is mounted using an attachment clip. The max. tension wire gauge is 10,0 mm. Different position of the stop surfaces enable variable installation options.</p>		
<b>Uni terminal block 6 PA, black</b>	<p>Material: PA-GF            Colour: black            Gap dimension = 5,0 mm (circumferential)            m = 8,0 g</p>	<b>UKB6</b>	
			
<b>Uni terminal block 8 PA, black</b>	<p>Material: PA-GF            Colour: black            Gap dimension = 6,0 mm (circumferential)            m = 9,0 g</p>	<b>UKB8</b>	

## MULTIBLOCKS

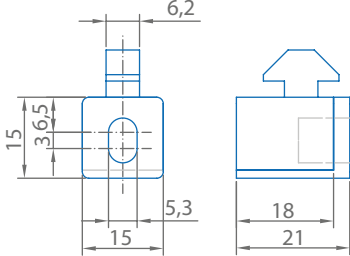
ITEM	Description	Order no.	Drawing
	<p>Multiblocks enable the reliable and secure attachment of any surface elements to the profile groove. Multiblocks can be retrofitted at any time in constructions. The installation position can be freely selected by screwing it into the profile groove. For a larger mounting clearance provide an oblong hole and a movable fixing nut. An interchangeable height compensation and a rotatable installation position ensure variable installation dimensions.</p>		
<b>Multiblock 6 PA, black</b>	<p>Base plate and height compensation            Material: PA-GF            Colour: black            Square nut DIN 557-M5, St, galvanised            Load: max. 150 N            m = 6,0 g</p>	<b>MB6-PA-M5</b>	

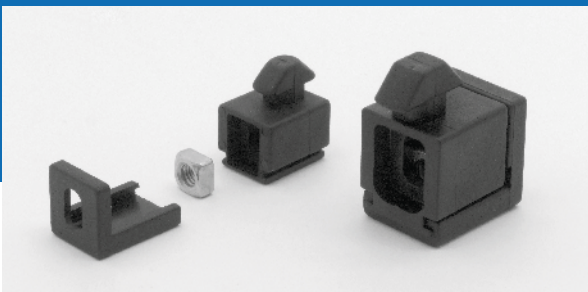









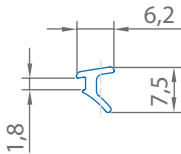

MULTIBLOCKS			
ITEM	Description	Order no.	Drawing
	Multiblocks enable the reliable and secure attachment of any surface elements to the profile groove. Multiblocks can be retrofitted at any time in constructions. The installation position can be freely selected by screwing it into the profile groove. For a larger mounting clearance provide an oblong hole and a movable fixing nut. An interchangeable height compensation and a rotatable installation position ensure variable installation dimensions.		
<b>Multiblock 8 PA, black</b>			
	Base plate and height compensation Material: PA-GF Colour: black Square nut DIN 557-M6, St, galvanised Spring plate, St, galvanised Load: max. 250 N m = 12,5 g	<b>MB8-PA-M6</b>	
<b>Multiblock 8 PC, lucent</b>			
	Base plate and height compensation Material: PC Colour: transparent Square nut DIN 557-M6, St, galvanised Spring plate, St, galvanised Load: max. 250 N m = 12,0 g	<b>MB8-PC-M6-T</b>	

Fixation  
elements

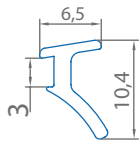
MULTIBLOCK ZN			
ITEM	Description	Order no.	Drawing
	For fixing surfaces to the profile groove, especially under high loads. The Multiblock Zn is attached to the profile groove by screw and T-slot. The supplied notch allows different installation heights. For fastening the panel element there are optionally a through bore or a square nut available.		
<b>Multiblock 8 Zn</b>			
	Base plate and notch Material: die-cast zinc Colour: black powder coated Square nut DIN 557-M6, St, galvanised Spring plate, St, stainless Load: max. 1.000 N m = 68,5 g	<b>MB8-ZN-M6</b>	

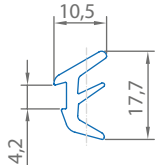

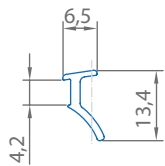

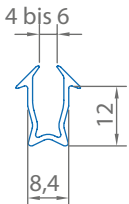

# FIXATION ELEMENTS

LIP SEALS			
ITEM	Description	Order no.	Drawing
	Lip seals are used to fix and seal surface elements of different thicknesses in the profile groove. The elastic material is resistant to detergent. For easy installation, it is recommended to moisten them with soapy water before installation. The locking of the sealing profiles in the profile groove is carried out by pressing in.		
	Material: TPE Colour: black a: 2-3 mm Rolls: 20 m/100 m m = 15,0 g/m	<b>DP5-2-3</b>	
	Material: TPE Colour: black a: 2-4 mm Rolls: 20 m/100 m m = 20,0 g/m	<b>DP6-2-4</b>	
	Material: TPE Colour: black a: 2-4 mm Rolls: 20 m/100 m m = 69,5 g/m	<b>DP8-2-4</b>	
	Material: TPE Colour: black a: 4-6 mm Rolls: 20 m/100 m m = 29,5 g/m	<b>DP8-4-6</b>	
	Material: TPE Colour: black a: 4-6 mm Rolls: 20 m/100 m m = 50,0 g	<b>EP8-4-6</b>	

## COVER- AND DOUBLE-LID PROFILES

	Use as a cover profile for closing the profile groove against dirt and as a border profile for receiving panel elements. Other cover- and double-lid profiles in color and a detailed drawing can be found in the chapter „cover elements“.					
ITEM	Colour	a	m	Material	1 rod	Order no.
		[ mm ]	[ g/m ]		à	
<b>Cover- and double-lid profile 5</b>	natural	1,5 - 2,0	12,0	PP	2.000 mm	<b>AEP5-N</b>
<b>Cover- and double-lid profile 6</b>	natural	2,0 - 3,5	16,5	PP	2.000 mm	<b>AEP6-N</b>
<b>Cover- and double-lid profile 8</b>	natural	4,0 - 5,5	22,0	PP	2.000 mm	<b>AEP8-N</b>

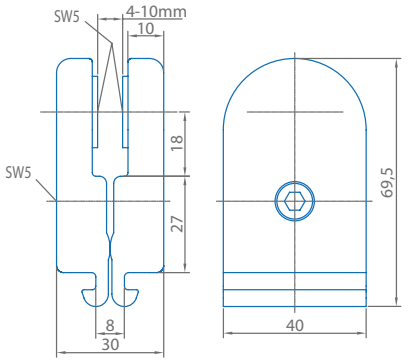

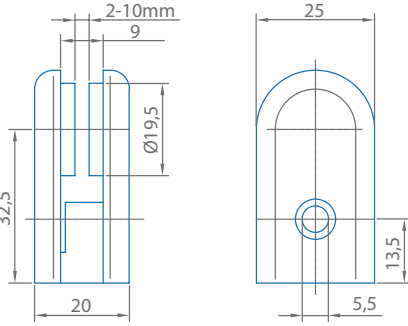



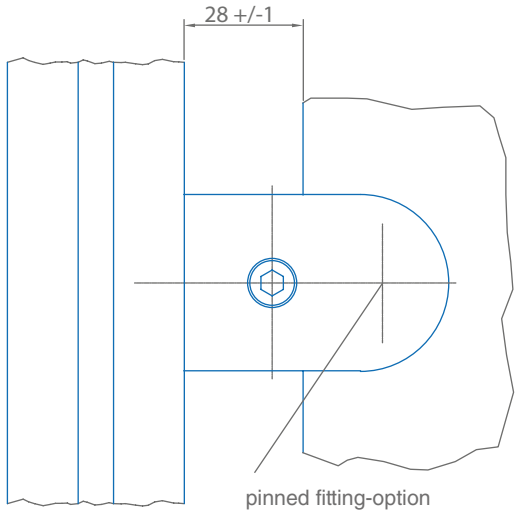
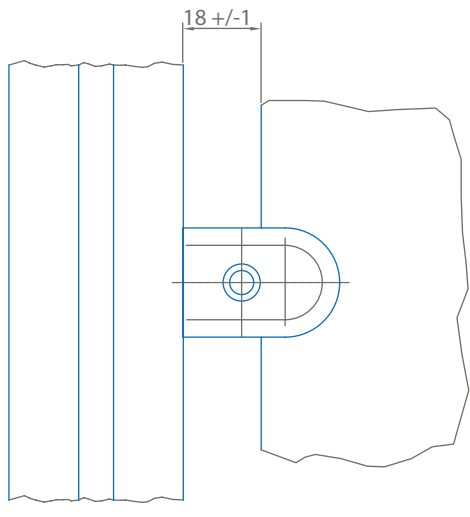

PANEL BRACKETS			
ITEM	Description	Order no.	Drawing
	With the panel clamp or the glass panel bracket, panel elements can be attached to the profile without additional processing. The panel clamp is fixed to the panel element by tightening the clamping screws. This type of fixing is particularly suitable for frameless panes.		
<b>Panel clamp 8</b> 	2 housing halves, PA-GF, black 1 hexagon socket DIN 912-M6x20, St, galvanised 1 hexagon nut DIN 934-M6, St, galvanised 2 washers, NBR, black m = 52,0 g	<b>Z8-PA</b>	
<b>Glass panel bracket 8</b> 	2 housing halves, die-cast zinc Colour: aluminium powder-coated Holder Assembly set: Rubber plates, screw M5x16 galvanised m = 74,0 g	<b>GSH-8</b>	

fixation elements

INSTALLATION-PITCH AREA	
Clamp 8 - installation-pitch area	Glass panel bracket 8 - installation-pitch area
	

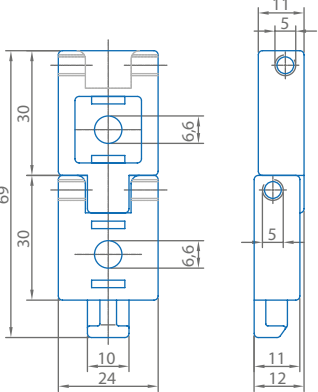

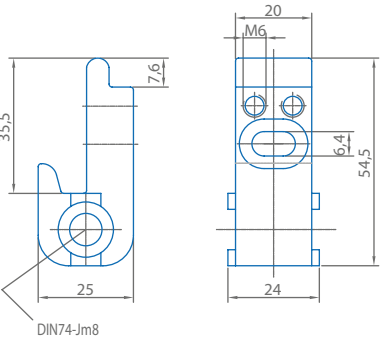
# FIXATION ELEMENTS

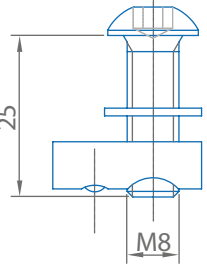
HANGERS			
ITEM	Description	Order no.	Drawing
	<p>Hangers are used for fastening frame elements to vertical profiles. If required, the hangers can be connected to each other using screws and thereby protected against being unhinged. For each connection point, two hangers 8 as well as the corresponding fastening sets are required.</p>		
<b>Hanger 6-8</b> 	2 mounts, die-cast zinc, black 2 anti-rotation devices, die-cast zinc, black 1 grub screw DIN 913-M5x10, black m = 68,0 g	<b>AH6/8-SZ</b>	
			
<b>Hanger 8</b> 	1 hanger, die-cast zinc, black 1 hexagon socket DIN 912-M6x16, St, galvanised 1 washer DIN 125-6.4, St, galvanised m = 88,0 g	<b>AH8</b>	
<b>Fastening set 8 for hanger 8</b> 	1 button-head screw ISO 7380-M8x25, St, galvanised 1 washer 13,5x9x1, St, galvanised 1 T-Slot 8 St M8, galvanised m = 22,0 g	<b>BS8-AH</b>	

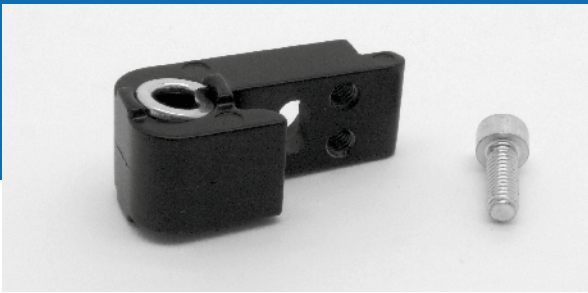

SAFETY HANGER			
ITEM	Description	Order no.	Drawing
	The safety hanger 8/8, galvanised is a robust and break-proof hanger for fastening profile frames to upright profiles. Both the frame as well as the upright is made of series 8 profiles. The safety hanger is easy to install and provides with tamper-proof screws effective protection. The component complies with the requirements of the machinery directive 2006/42/EC. For each profile frame, one set of the safety hanger is required.		
<b>Safety hanger 8/8, galvanised</b>			
	Safety hanger, St, galvanised Fastening set, St, galvanised m = 978,0 g	<b>SI-AH8/8-VZ</b>	

DOOR RABBET			
ITEM	Description	Order no.	Drawing
	The door rabbet 8 serves as a stop for swing doors and thus prevents doors from swinging through.		
<b>Door rabbet 8</b>			
	2 door hinges, die-cast zinc Surface: black powder-coated Gap dimension door stop side: 22 mm Gap dimension hinge side: 28 mm m = 150,0 g	<b>TASCH8-SZ</b>	
<b>Fastening set for door rabbet 8</b>			
	2 button-head screws ISO 7380-M8x25, St, galvanised 2 washers 13,5x9x1, St, galvanised 2 T-Slots 8 St M8, galvanised m = 44,0 g	<b>BS8-TA</b>	

Fixation elements



# FIXATION ELEMENTS

## CONNECTION SIZES FOR HINGES PA

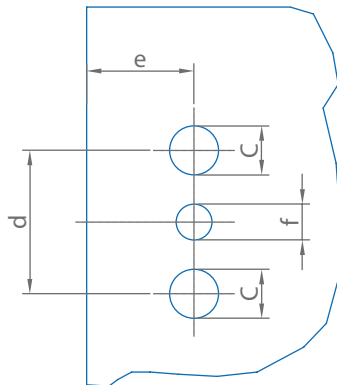

## TECHNICAL INFO

Screw	M5x8		M5x14		M6x16	
Bore hole C	Ø 5,0		Ø 6,3		Ø 8,2	
d	15 mm		22 mm		24 mm	
e	9 mm		14 mm		18 mm	
f	M5		M5		M6	
F	50 N		75 N		100 N	

## HINGE 8 AL

ITEM	Description	Order no.	Drawing
	Hinge 8 Al PP4 light is suitable for swing doors and flaps with medium-heavy load. The hinges can be mounted both as top hinges and in the door gap (between door and frame). A gap of 4,0 mm must be provided at the hinge. The advantage of mounting in the door gap is that the fastening screws are covered when the door is closed and cannot be removed.		
<b>Hinge 8 Al PP4, light</b>	 <p>Hinge halves: Al, anodised            Hinge pin: stainless steel (A2)            2 cover caps: PA-GF, grey            2 T-slot nuts 8 St M6 with guiding ridge, galvanised            2 countersunk screws DIN 7991 M6x14, galvanised            m = 113,0 g</p>	<b>SCH8-AL-PP4</b>	

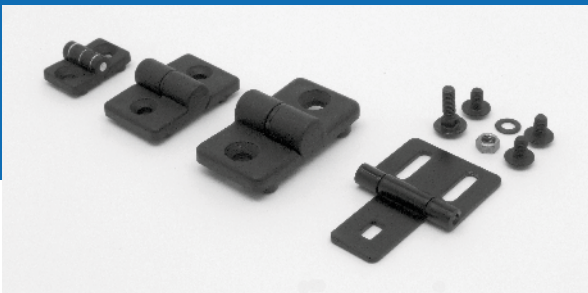

HINGE ST			
ITEM	Description	Order no.	Drawing
	Hinges St are suitable for light flaps and doors. Installation can optionally be external or internal. In the add-on version hinges St cannot be released from outside. The opening angle of the hinge is 180°.		
<b>Hinge St</b>			
	<p>Hinge halves, St, black powder-coated            3 pan-head flange screws M5x8,            St, black            Hexagon nut DIN 934-M5,            St, black            Washer DIN125-5.3, St, black            Saucer-head screw DIN 603-M5x16,            St, black            m = 50,5 g</p>	<b>SCH-ST</b>	

Fixation  
 elements

HINGES PA			
ITEM	Description	Order no.	Drawing
	Hinges PA are well-suited for light doors and flaps. They are equipped with an anti-rotation lock which is inserted into the profile groove. Surface elements which are fastened using hinges PA have to be processed with through bores C (see table).		
<b>Hinge 5 PA</b>			
	<p>Material: PA-GF            Colour: black            non-detachable            m = 6,0 g</p>	<b>SCH5-PA</b>	



# FIXATION ELEMENTS

HINGES PA			
ITEM	Description	Order no.	Drawing
	<p>Hinges PA are suitable for light doors and flaps. They are equipped with an anti-rotation device that engages in the profile groove. Area elements, which are fastened directly with hinges PA, must be machined with bore holes C (see table). Door elements of series 6 and 8 can be mounted in such a way that they can be subsequently lifted out or permanently mounted. Hinges right and left can be combined.</p>		
<b>Hinge 6 PA, right</b>			
	PA-GF, black Pin, St, galvanised Washer, PA, black m = 13,5 g	<b>SCH6-PA-R</b>	
<b>Hinge 6 PA, left</b>			
	PA-GF, black Pin, St, galvanised Washer, PA, black m = 13,5 g	<b>SCH6-PA-L</b>	
<b>Double hinge 8 PA</b>			
	PA-GF, black 2 straight pins, St, galvanised 2 washers, PA, black m = 25,0 g	<b>DSCH6-PA</b>	









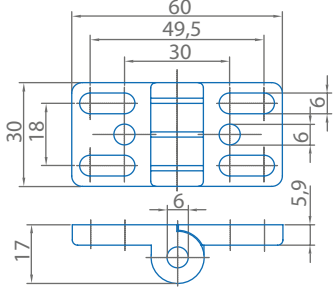

HINGES PA			
ITEM	Description	Order no.	Drawing
<b>Hinge 8 PA, right</b>			
	PA-GF, black Pin, St, galvanised Washer, PA, black m = 20,5 g	<b>SCH8-PA-R</b>	
<b>Hinge 8 PA, left</b>			
	PA-GF, black Pin, St, galvanised Washer, PA, black m = 20,5 g	<b>SCH8-PA-L</b>	
<b>Double hinge 8 PA</b>			
	PA-GF, black 2 straight pins, St, galvanised 2 washers, PA, black m = 37,5 g	<b>DSCH8-PA</b>	

Fixation elements

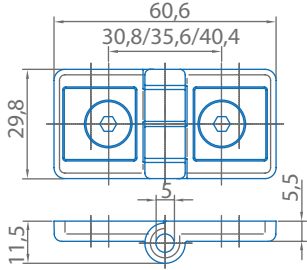

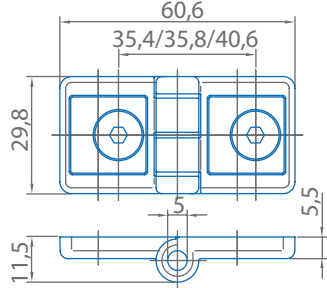

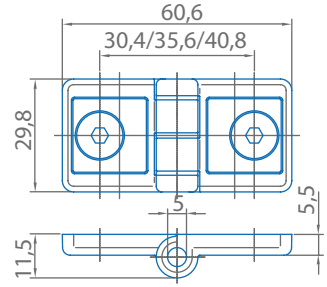

# FIXATION ELEMENTS



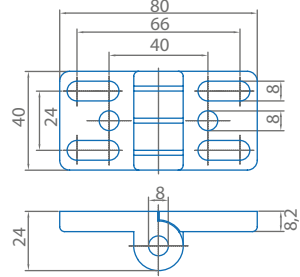

HINGES ZN			
ITEM	Description	Order no.	Drawing
	Hinges Zn are universal hinges for flaps and doors with higher loads. Furthermore, profiles can also be connected in any angle. Integrated anti-rotation devices for additional fixing in the groove are available. These can optionally be removed.		
<b>Hinge 6 30 Zn</b> 	Hinge, die-cast zinc, black powder-coated m = 67,5 g	<b>SCH6-30-ZN</b>	
<b>Hinge 6 30 Zn 6/6</b> 	Hinge, die-cast zinc, black powder-coated 2 locking devices 6, die-cast zinc, black 2 countersunk screws DIN 7991-M5x14, St, black m = 66,0 g	<b>SCH30-ZN-6/6</b>	
			
<b>Hinge 6 30 Zn 6/8</b> 	Hinge, die-cast zinc, black powder-coated 1 locking device 6, die-cast zinc, black 1 locking device 8, die-cast zinc, black 1 countersunk screw DIN 7991-M5x14, St, black 1 countersunk screw DIN 7991-M5x16, St, black m = 66,5 g	<b>SCH30-ZN-6/8</b>	
			
<b>Hinge 6 30 Zn 8/8</b> 	Hinge, die-cast zinc, black powder-coated 2 locking devices 8, die-cast zinc, black 2 countersunk screws DIN 7991-M5x16, St, black m = 66,5 g	<b>SCH30-ZN-8/8</b>	

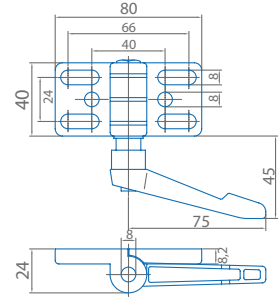

## HINGES ZN

ITEM	Description	Order no.	Drawing
			
<b>Hinge 8 40 Zn</b>			
	Hinge, die-cast zinc, black powder-coated m = 185,0 g	<b>SCH8-40-ZN</b>	
<b>Hinge 8 40 Zn with damp lever</b>			
	Hinge, die-cast zinc, black powder-coated Clamp lever, PA-GF, black m = 210,5 g	<b>SCH8-40-ZN-KH</b>	

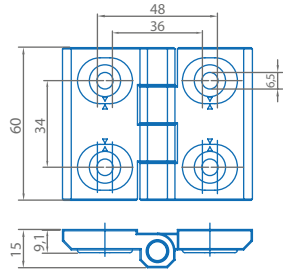
## HINGES 2D

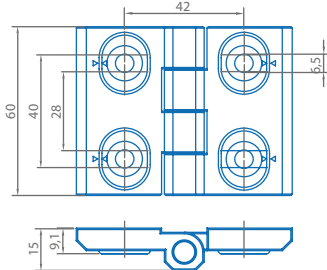
ITEM	Description	Order no.	Drawing
	Hinges 2D are robust universal hinges for flaps and doors with higher loads. With the supplied adjustment washers the door gap can be individually adjusted within a range of 0-8 mm. Fastening to the profile groove is carried out via T-slots and countersunk screws M6.		
<b>Hinge 2D 76x60 Zn, black adjustable in width</b>			
	Hinge, die-cast zinc, black powder-coated Axle, stainless steel (A2) Load: $F_{max} = 1.200\text{ N}$ Bore hole: 34,0 mm (height) Bore hole: 38-46,0 mm (width) m = 202,0 g	<b>SCH8-2D-B</b>	
<b>Hinge 2D 76x60 Zn, black adjustable in height</b>			
	Hinge, die-cast zinc, black powder-coated Axle, stainless steel (A2) Load: $F_{max} = 1.200\text{ N}$ Bore hole: 42,0 mm (width) Bore hole: variable 34-38,0 mm (height) m = 202,0 g	<b>SCH8-2D-H</b>	



# FIXATION ELEMENTS

HEXAGON SOCKETS				
ITEM	Description	l	m	Order no.
		[ mm ]	[ g / 100 ]	
	Button-head screws, hexagon sockets and countersunk screws are available in various diameters, lengths and qualities.			
Hexagon sockets M5x8	DIN 6912 galvanised, property class 8.8	8,0	215,5	ZS5x8
Hexagon sockets M6x16	DIN 6912 galvanised, property class 8.8	16,0	550,0	ZS6x16
Hexagon sockets M8x40	DIN 6912 galvanised, property class 8.8	40,0	1.945,0	ZS8x40

COUNTERSUNK SCREWS				
ITEM	Description	l	m	Order no.
		[ mm ]	[ g / 100 ]	
Countersunk screws M5x8	ISO 7991, St black, natural, property class 10.9	8,0	160,0	SS5x8
Countersunk screws M6x10	ISO 7991, St black, natural, property class 10.9	10,0	275,0	SS6x10
Countersunk screws M6x14	ISO 7991, St black, natural, property class 10.9	14,0	344,0	SS6x14
Countersunk screws M8x14	ISO 7991, St black, natural, property class 10.9	14,0	643,0	SS8x14
Countersunk screws M8x16	ISO 7991, St black, natural, property class 10.9	16,0	710,0	SS8x16

BUTTON-HEAD SCREWS				
ITEM	Description	l	m	Order no.
		[ mm ]	[ g / 100 ]	
Button-head screw M4x6	ISO 7380, St, galvanised, property class 10.9	6,0	93,0	HS4x6
Button-head screw M4x8	ISO 7380, St, galvanised, property class 10.9	8,0	107,5	HS4x8
Button-head screw M4x10	ISO 7380, St, galvanised, property class 10.9	10,0	118,5	HS4x10
Button-head screw M4x12	ISO 7380, St, galvanised, property class 10.9	12,0	137,0	HS4x12
Button-head screw M4x14	ISO 7380, St, galvanised, property class 10.9	14,0	149,0	HS4x14
Button-head screw M4x16	ISO 7380, St, galvanised, property class 10.9	16,0	160,5	HS4x16
Button-head screw M4x20	ISO 7380, St, galvanised, property class 10.9	20,0	198,0	HS4x20
Button-head screw M4x25	ISO 7380, St, galvanised, property class 10.9	25,0	229,5	HS4x25
Button-head screw M5x8	ISO 7380, St, galvanised, property class 10.9	8,0	182,0	HS5x8
Button-head screw M5x10	ISO 7380, St, galvanised, property class 10.9	10,0	208,0	HS5x10
Button-head screw M5x12	ISO 7380, St, galvanised, property class 10.9	12,0	239,5	HS5x12
Button-head screw M5x14	ISO 7380, St, galvanised, property class 10.9	14,0	258,5	HS5x14



## BUTTON-HEAD SCREWS

ITEM	Description	l	m	Order no.
		[ mm ]	[ g / 100 ]	
Button-head screw M5x16	ISO 7380, St, galvanised, property class 10.9	16,0	278,0	HS5x16
Button-head screw M5x20	ISO 7380, St, galvanised, property class 10.9	20,0	338,5	HS5x20
Button-head screw M5x25	ISO 7380, St, galvanised, property class 10.9	25,0	382,5	HS5x25
Button-head screw M5x30	ISO 7380, St, galvanised, property class 10.9	30,0	450,5	HS5x30
Button-head screw M6x10	ISO 7380, St, galvanised, property class 10.9	10,0	289,5	HS6x10
Button-head screw M6x12	ISO 7380, St, galvanised, property class 10.9	12,0	337,5	HS6x12
Button-head screw M6x14	ISO 7380, St, galvanised, property class 10.9	14,0	342,5	HS6x14
Button-head screw M6x16	ISO 7380, St, galvanised, property class 10.9	16,0	390,5	HS6x16
Button-head screw M6x18	ISO 7380, St, galvanised, property class 10.9	18,0	440,0	HS6x18
Button-head screw M6x20	ISO 7380, St, galvanised, property class 10.9	20,0	464,5	HS6x20
Button-head screw M6x25	ISO 7380, St, galvanised, property class 10.9	25,0	543,5	HS6x25
Button-head screw M6x30	ISO 7380, St, galvanised, property class 10.9	30,0	633,0	HS6x30
Button-head screw M6x35	ISO 7380, St, galvanised, property class 10.9	35,0	711,5	HS6x35
Button-head screw M6x40	ISO 7380, St, galvanised, property class 10.9	40,0	861,5	HS6x40
Button-head screw M8x10	ISO 7380, St, galvanised, property class 10.9	10,0	610,5	HS8x10
Button-head screw M8x12	ISO 7380, St, galvanised, property class 10.9	12,0	671,5	HS8x12
Button-head screw M8x14	ISO 7380, St, galvanised, property class 10.9	14,0	743,0	HS8x14
Button-head screw M8x16	ISO 7380, St, galvanised, property class 10.9	16,0	780,0	HS8x16
Button-head screw M8x16	stainless - ISO 7380, St, stainless (A2)	16,0	809,5	HS8x16-R
Button-head screw M8x18	ISO 7380, St, galvanised, property class 10.9	18,0	854,5	HS8x18
Button-head screw M8x20	ISO 7380, St, galvanised, property class 10.9	20,0	917,5	HS8x20
Button-head screw M8x20	with shaft - ISO 7380, St, galvanised, property class 10.9	20,0	955,5	HS8x20-S
Button-head screw M8x20	stainless - ISO 7380, St, stainless (A2)	20,0	922,0	HS8x20-R
Button-head screw M8x25	ISO 7380, St, galvanised, property class 10.9	25,0	1.077,0	HS8x25
Button-head screw M8x30	ISO 7380, St, galvanised, property class 10.9	30,0	1.234,0	HS8x30
Button-head screw M8x30	stainless - ISO 7380, St, stainless (A2)	30,0	1.242,0	HS8x30-R
Button-head screw M8x35	ISO 7380, St, galvanised, property class 10.9	35,0	1.395,5	HS8x35
Button-head screw M8x40	ISO 7380, St, galvanised, property class 10.9	40,0	1.532,0	HS8x40
Button-head screw M8x45	ISO 7380, St, galvanised, property class 10.9	45,0	1.694,0	HS8x45
Button-head screw M8x50	ISO 7380, St, galvanised, property class 10.9	50,0	1.856,0	HS8x50
Button-head screw M8x80	ISO 7380, St, galvanised, property class 10.9	80,0	2.774,5	HS8x80