

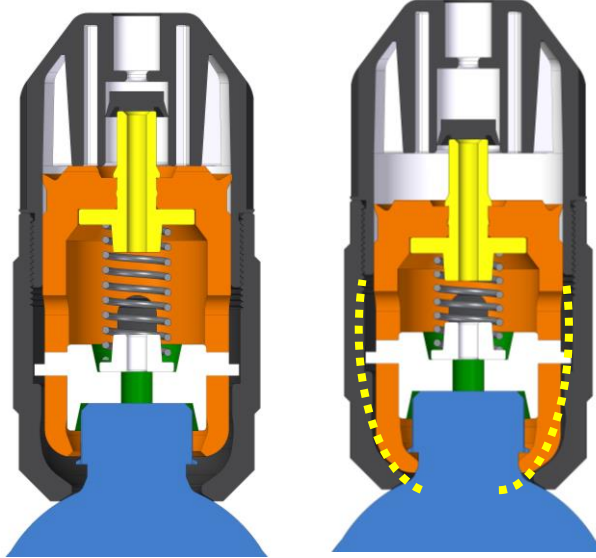

BOT-GRIPPER

Bottle Handling Solution

■ BOT-Gripper - BF28



■ BOT-Gripper - B040/ B045

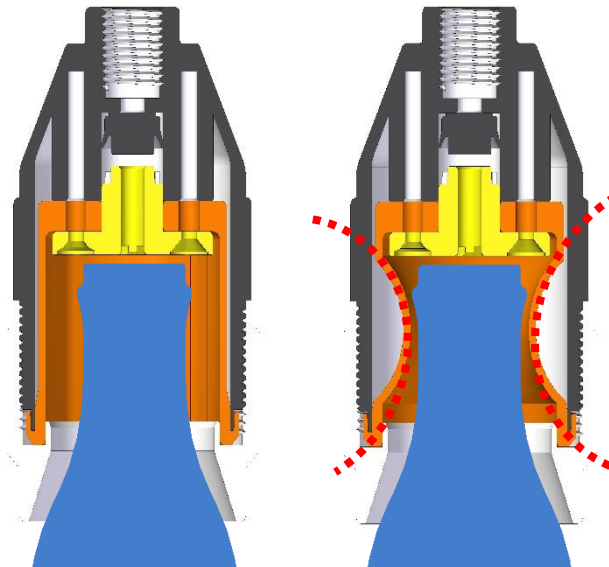

■ BOT-Gripper - BF28

Features and Strengths

- Finger style gripping
- Quick release function
- Longer life-span
- No wear and tear by the cap (crown cap)

Applications

- PET Bottle
- Bottle with crown cap



Structure

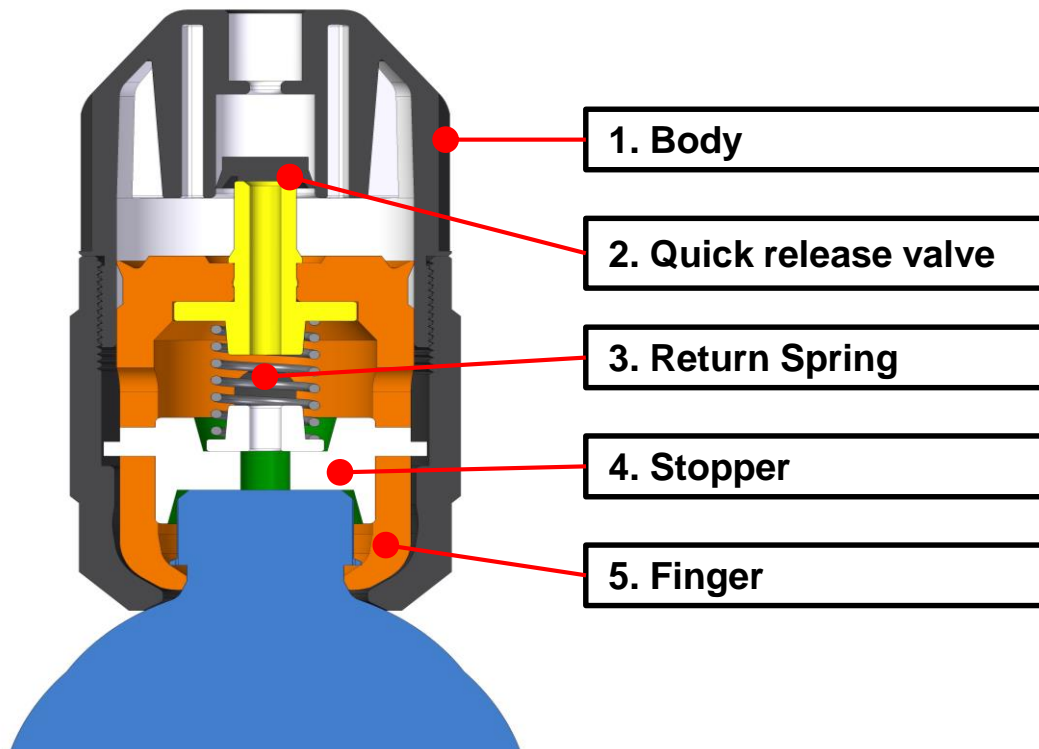

Principle of Operation

Once compressed air is supplied to the BF Gripper, quick release valve is pushed down by air pressure. Then the quick release valve close (block) the rapid outlet. With this down pressure, inner finger clamp is holding the head part of the PET bottles tightly.

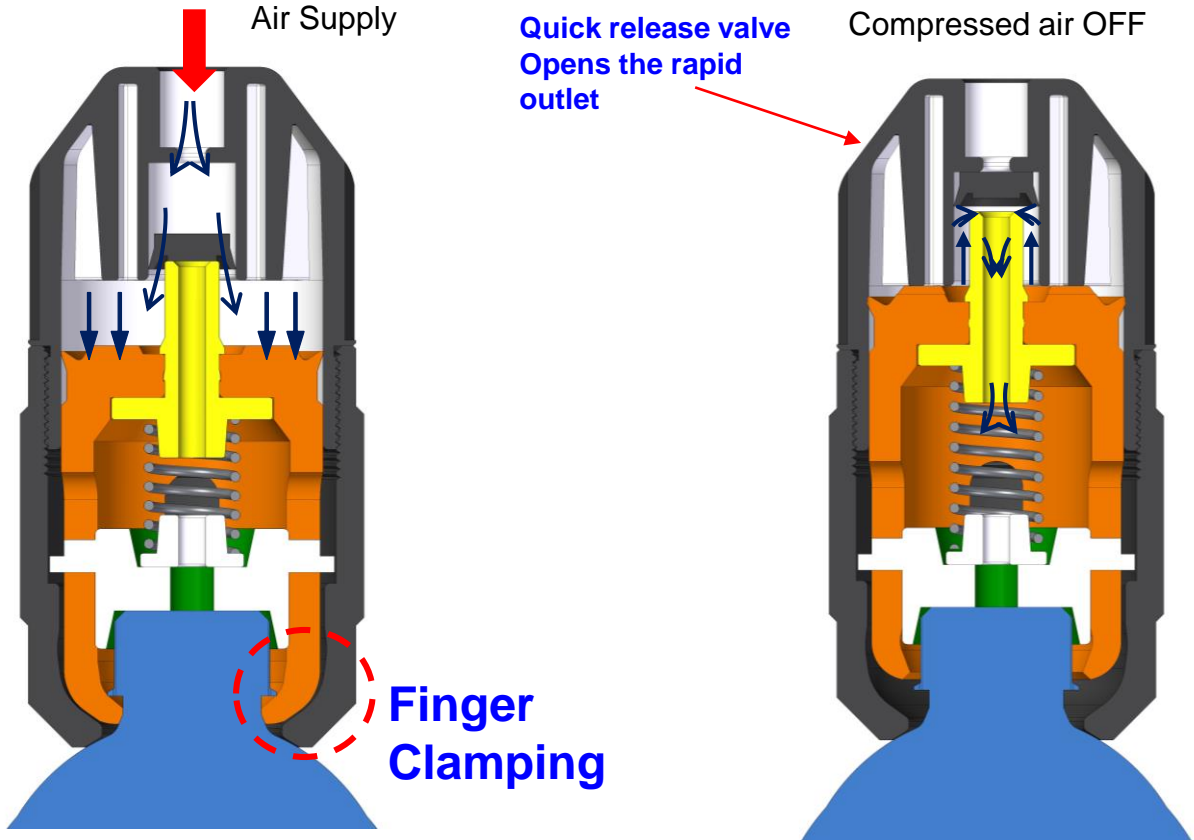

Dimensions & Specification

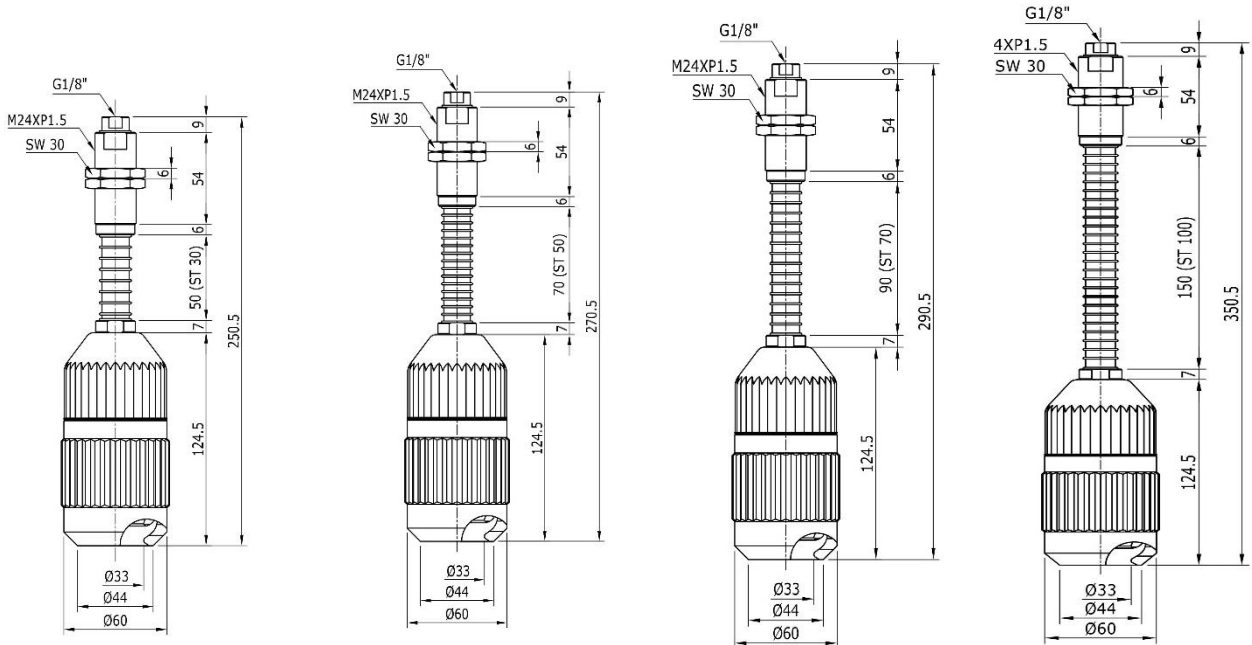

BF28-L30

BF28-L50

BF28-L70

BF28-L100

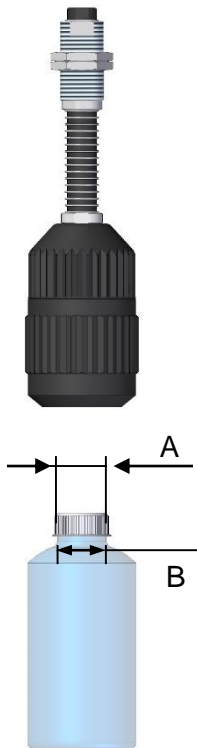

BF28	
Lifting Force	Max. 17 kg
Available Lifting diameter (A)	Min. Ø30 ~Max. Ø34
Available Lifting diameter (B)	Min. Ø24 ~Max. Ø29
Operating pressure	Min. 1.5 bar ~ Max. 4 bar (clamping)
Operating temperature	less than + 60 °C

Circuit

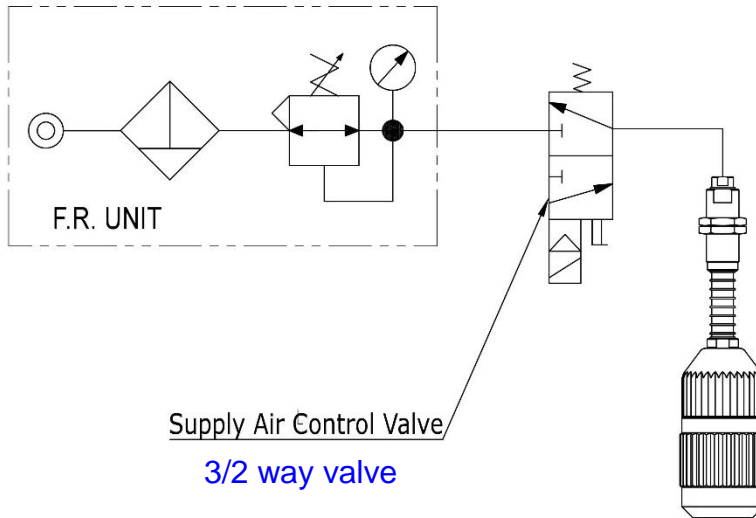

Build an Ordering No.

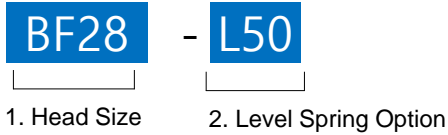

① Head Size

Symbol	Description
BF28	Bot-gripper, 28 Finger style

② Level Spring Option

Symbol	Description
L30	Level Spring Option, Stroke 30mm
L50	Level Spring Option, Stroke 50mm
L70	Level Spring Option, Stroke 70mm
L100	Level Spring Option, Stroke 100mm

■ BOT-Gripper - BO40/ BO45

Features and Strengths

- Pick up and transfer glass bottles or PET bottles.

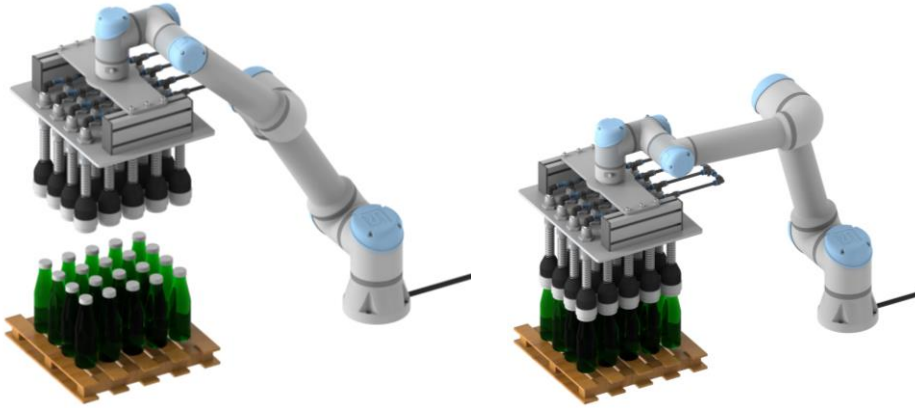

Structure

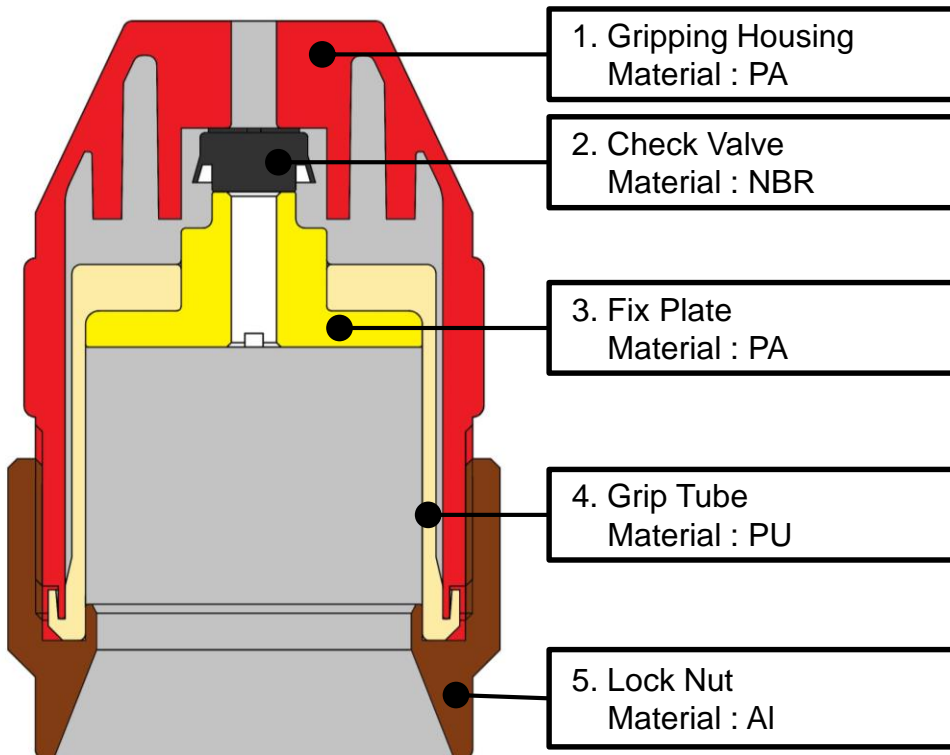

※ can order the SUS lock nut option by request

Principle of Operation

Once compressed air is supplied to pick-up head, check valve is pushed down by the compressed air and close (block) the rapid outlet, while the compressed air is supplied to the Grip Tube to inflate the Grip Tube and clamp the product.

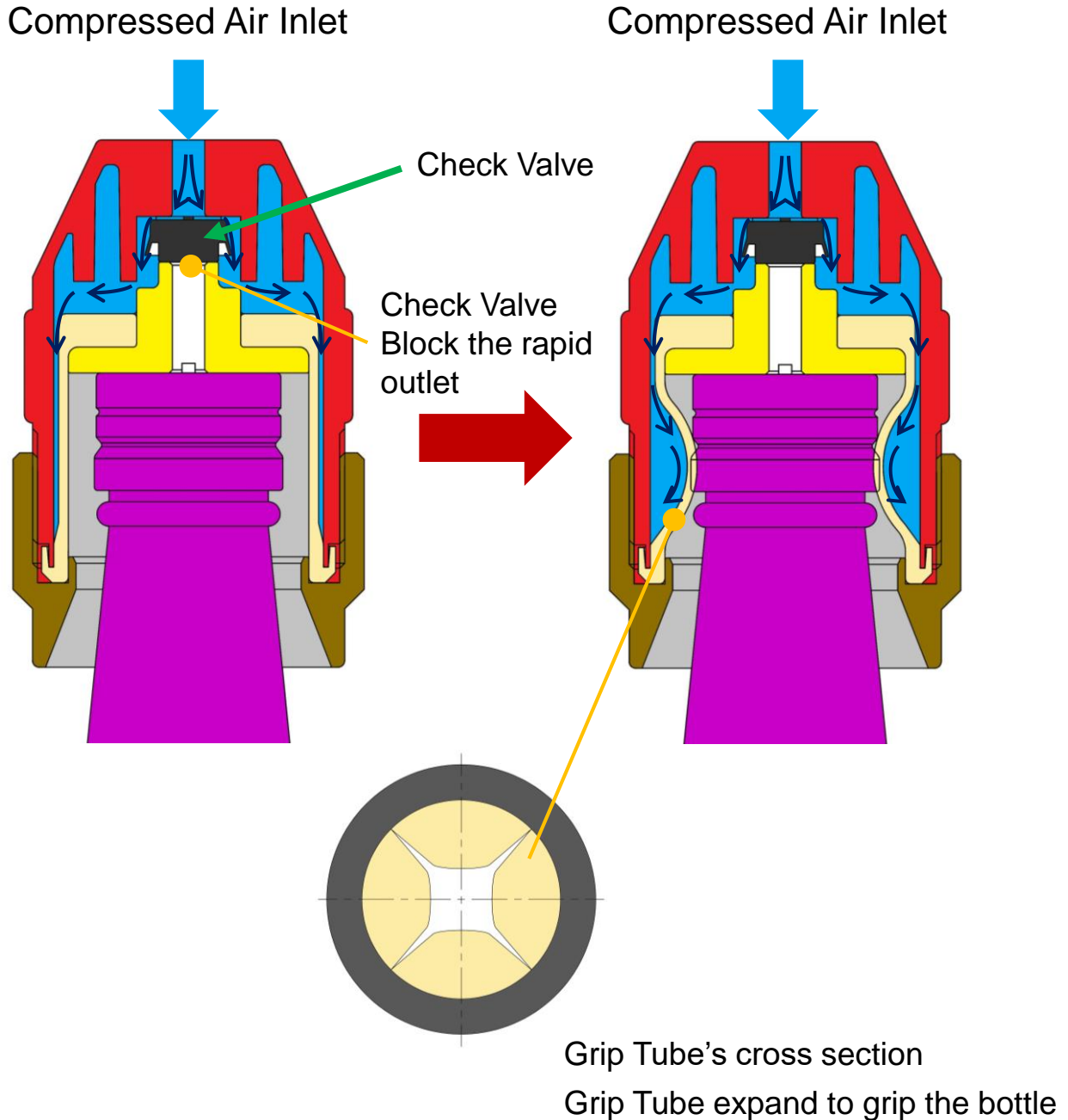

Principle of Operation

Once compressed air is stopped, check valve closes the air-inlet. The rapid outlet will be opened, and supplied air is vented out – and releases the product (bottle).

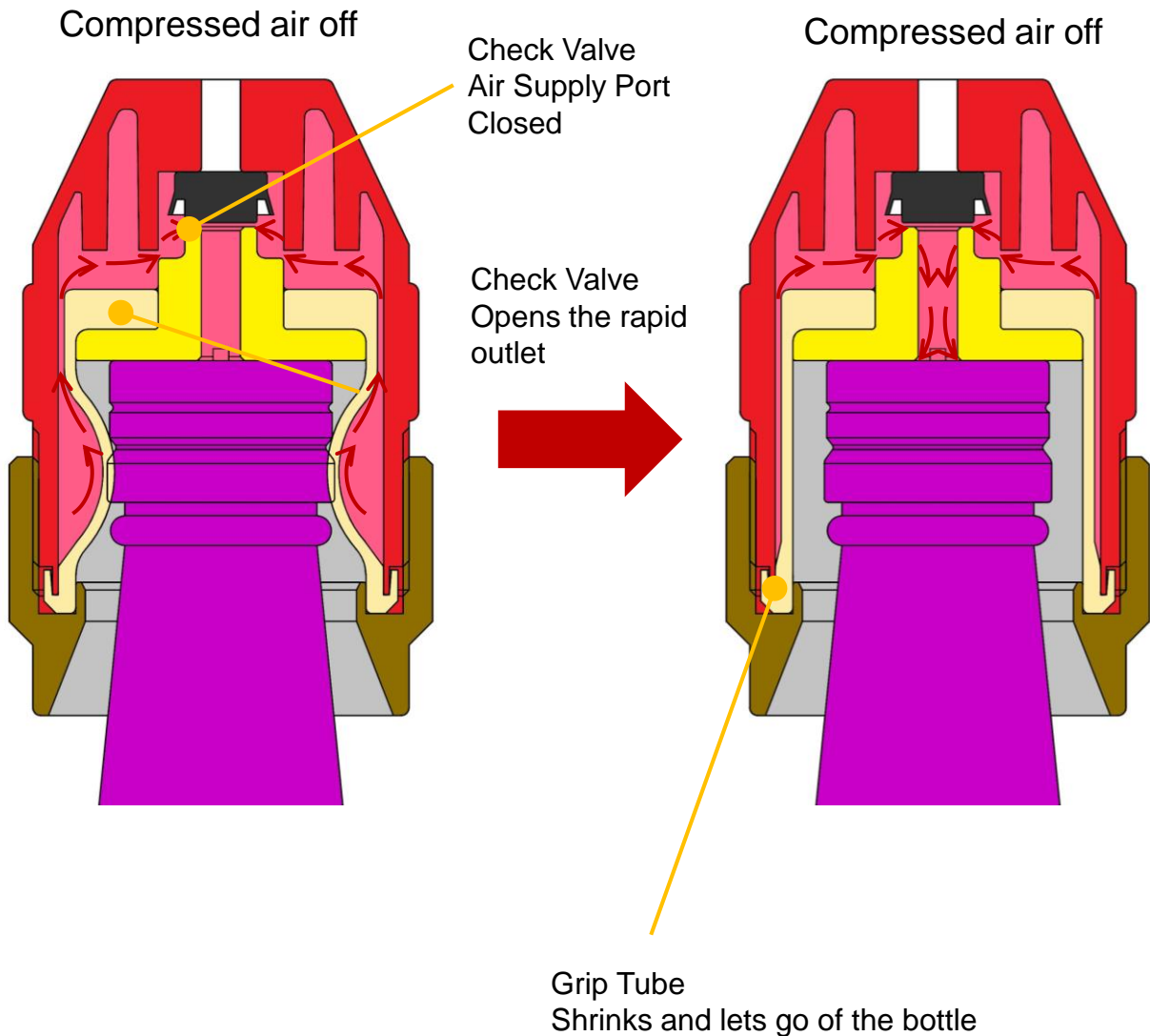

Dimensions & Specification

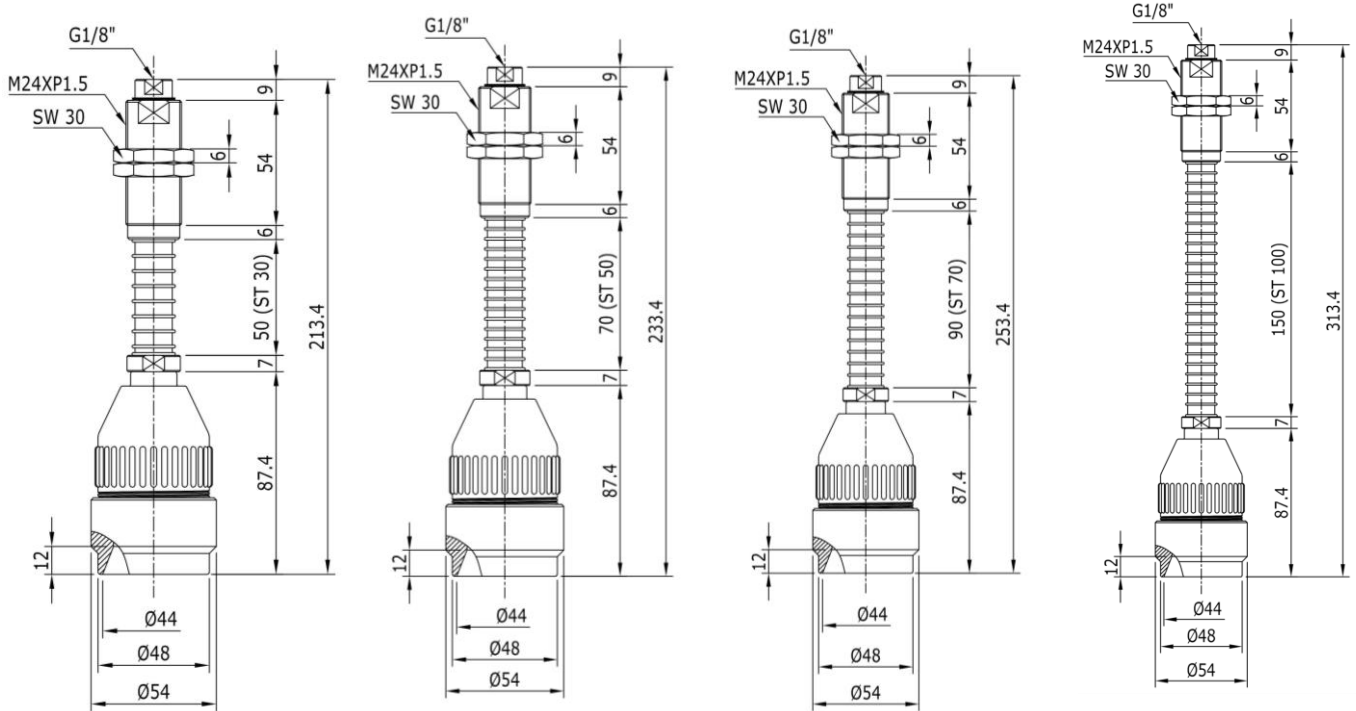

BO40-()-L30

BO40-()-L50

BO40-()-L70

BO40-()-L100

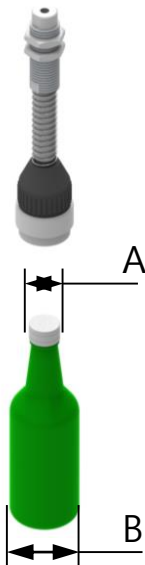

BO40	
Lifting Force	Max. 15 kg
Available Lifting diameter (A)	Min. Ø18 ~ Max. Ø32
Available Lifting diameter (B)	Min. Ø54
Operating pressure	(min) 1.5 bar ~ (max) 3.5 bar
Operating temperature	less than + 60 °C

Dimensions & Specification

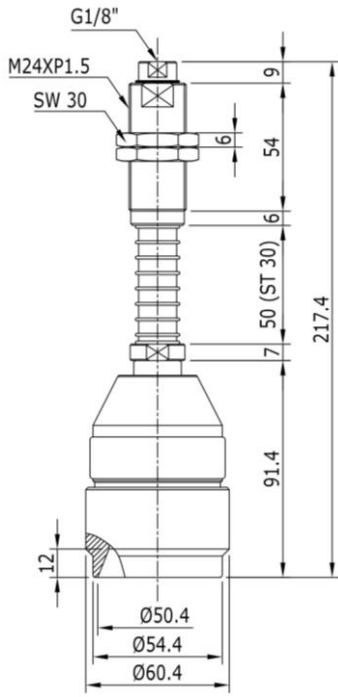

BO45-()-L30

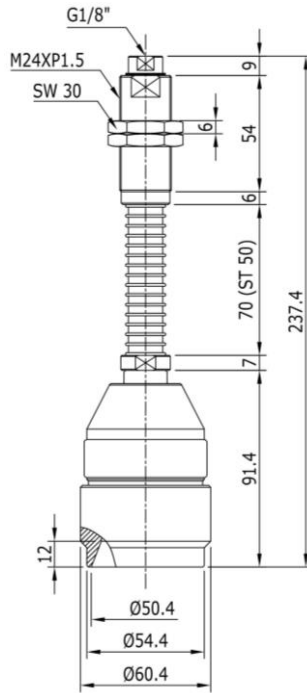

BO45-()-L50

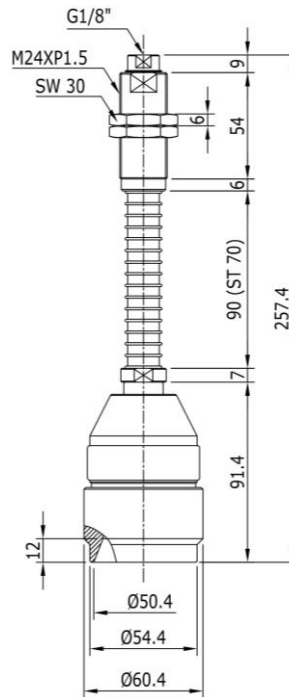

BO45-()-L70

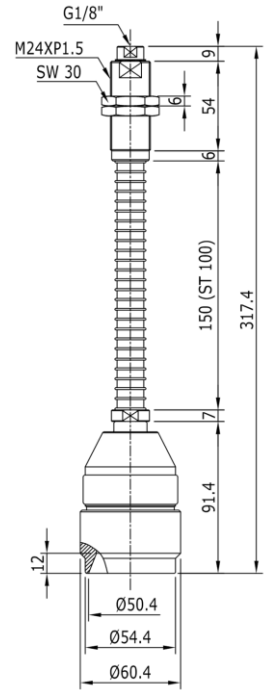

BO45-()-L100

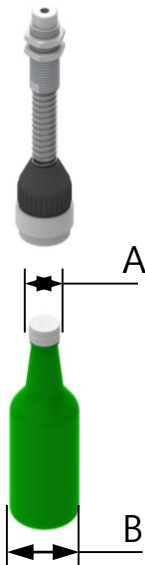

BO45	
Lifting Force	Max. 15 kg
Available Lifting diameter (A)	Min. Ø32 ~ Max. Ø45
Available Lifting diameter (B)	Min. Ø62
Operating pressure	(min) 1.5 bar ~ (max) 3.5 bar
Operating temperature	less than + 60 °C

Circuit

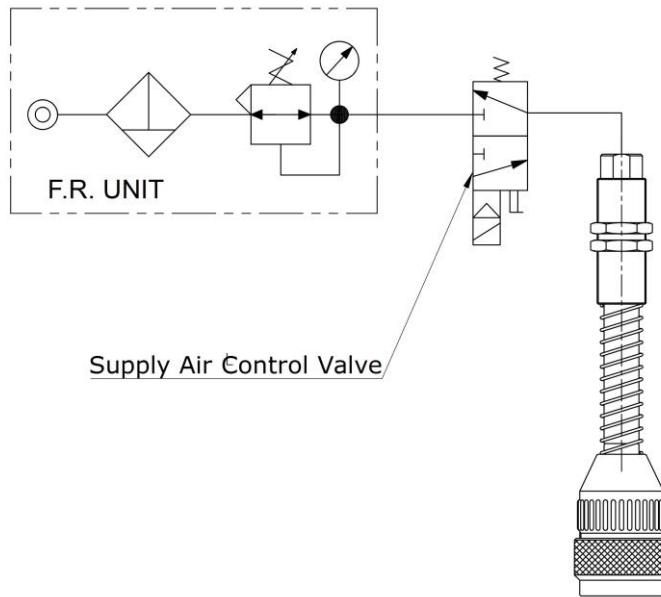

Build an Ordering No.

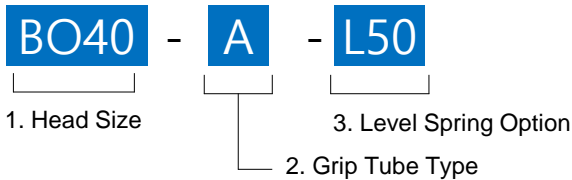

① Head Size

Symbol	Description
BO40	Head part, Bot-gripper, Min. Ø18 ~ Max. Ø32
BO45	Head part, Bot-gripper, Min. Ø32 ~ Max. Ø45

① Grip Tube Type

Symbol	Description
A	Standard Type
B	Anti-slip Bump Type

② Level Spring Option

Symbol	Description
L30	Level Spring Option, Stroke 30mm
L50	Level Spring Option, Stroke 50mm
L70	Level Spring Option, Stroke 70mm
L100	Level Spring Option, Stroke 100mm